

# Photovoltaic Inverter Trends



YOLE DÉVELOPPEMENT

# How is the 2010 Report Built?

## 4 chapters

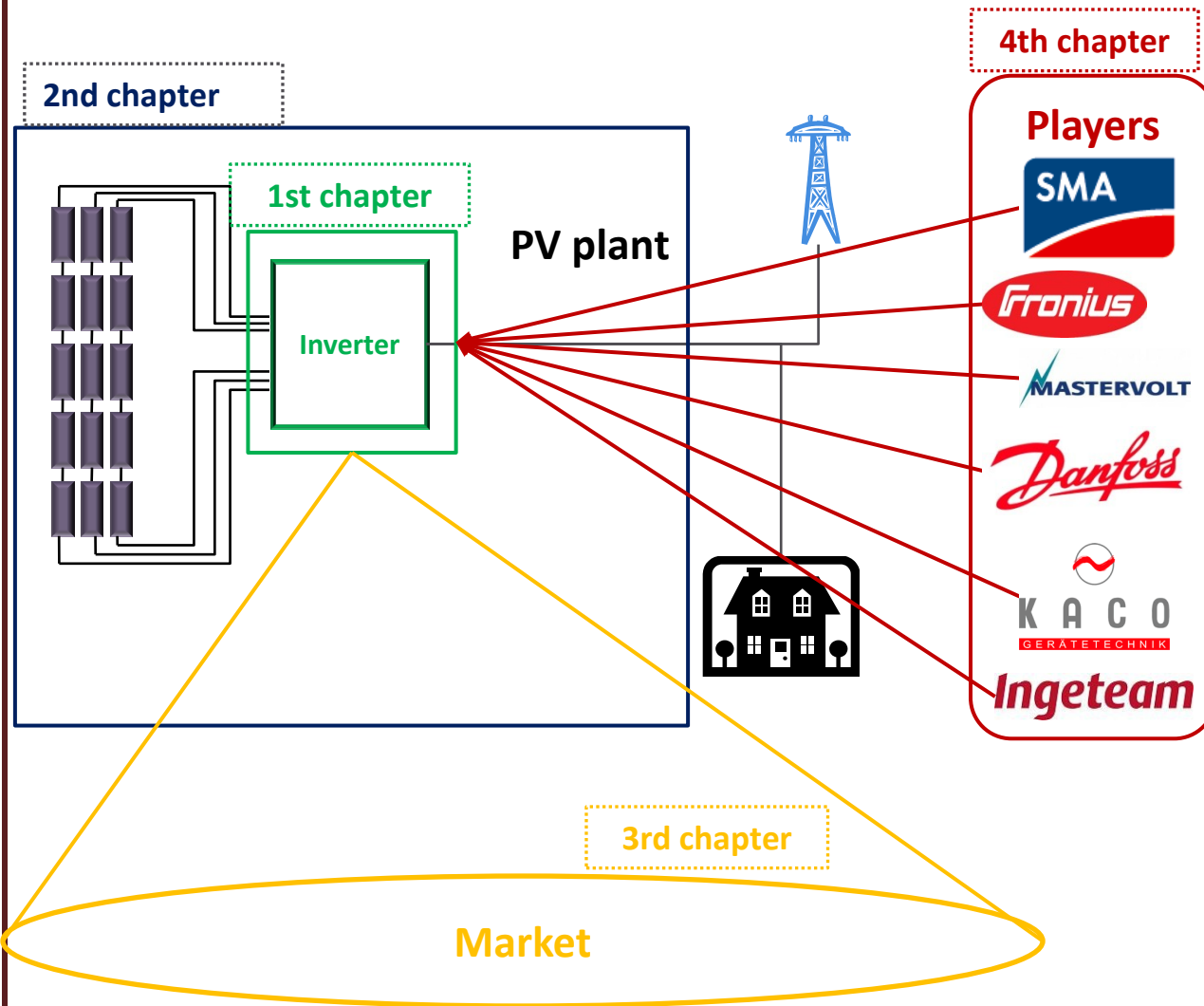





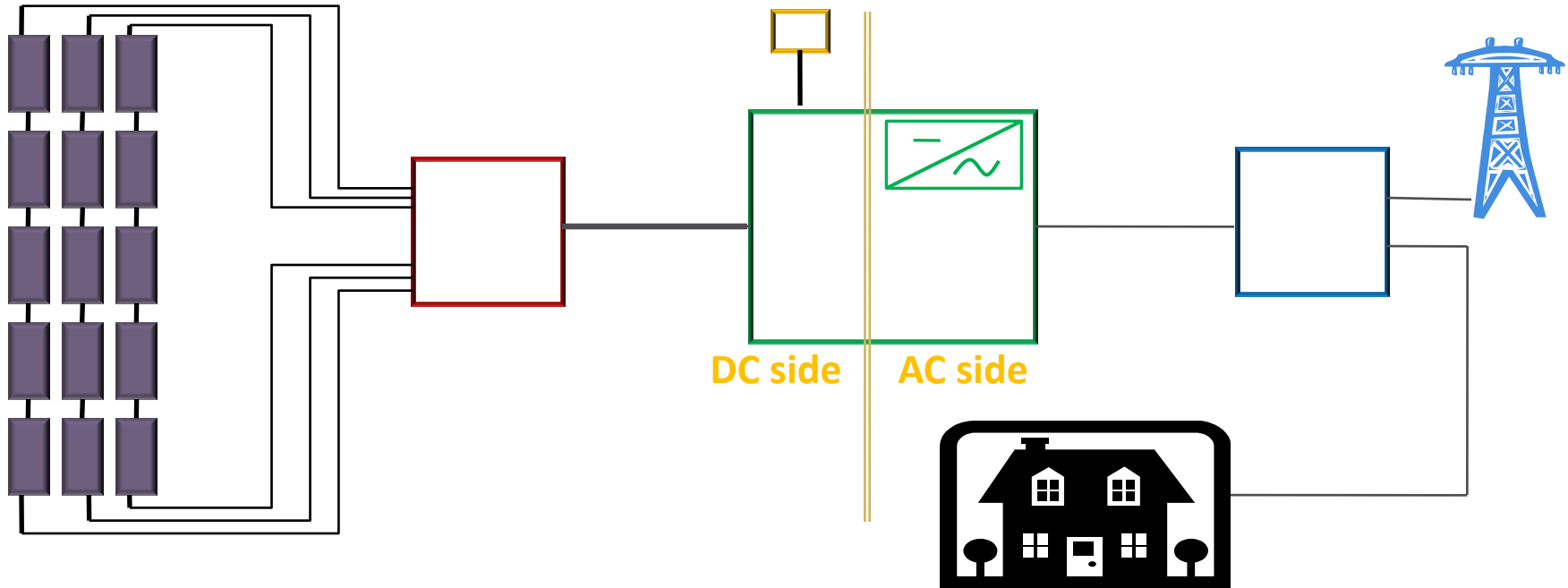
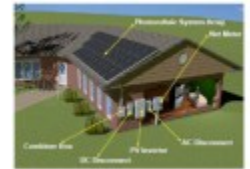

- In the **1st chapter**, we will describe the inverter as a system, explaining the relevant characteristics and parameters, as well as the future trends.
- In the **2nd chapter**, we will integrate the inverter in its environment and analyze the different architectures an inverter can fit in.
- In the **3rd chapter**, we will present some forecasts of the PV inverter market.
- In the **4th chapter** we will present some major players of this business and develop some parts of their strategies that we have perceived.

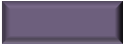
# Definition of Terminology Used



- Elements that compose the fundamental architecture of PV installations:

- PV modules or PV panels 
- PV strings 
- Main strings 
- DC string box, including protection 
- Monitoring system 
- DC/AC inverter or PV inverter 
- AC protection box 

- For the whole report, a PV plant will also be called an *installation*.

# PV Inverters: the system

## Definition

- Today, three main factors are driving the PV inverter evolution and, thus, the manufacturer behavior:

- Efficiency
- Cost
- Reliability
- **+ ADDITIONAL FEATURES**

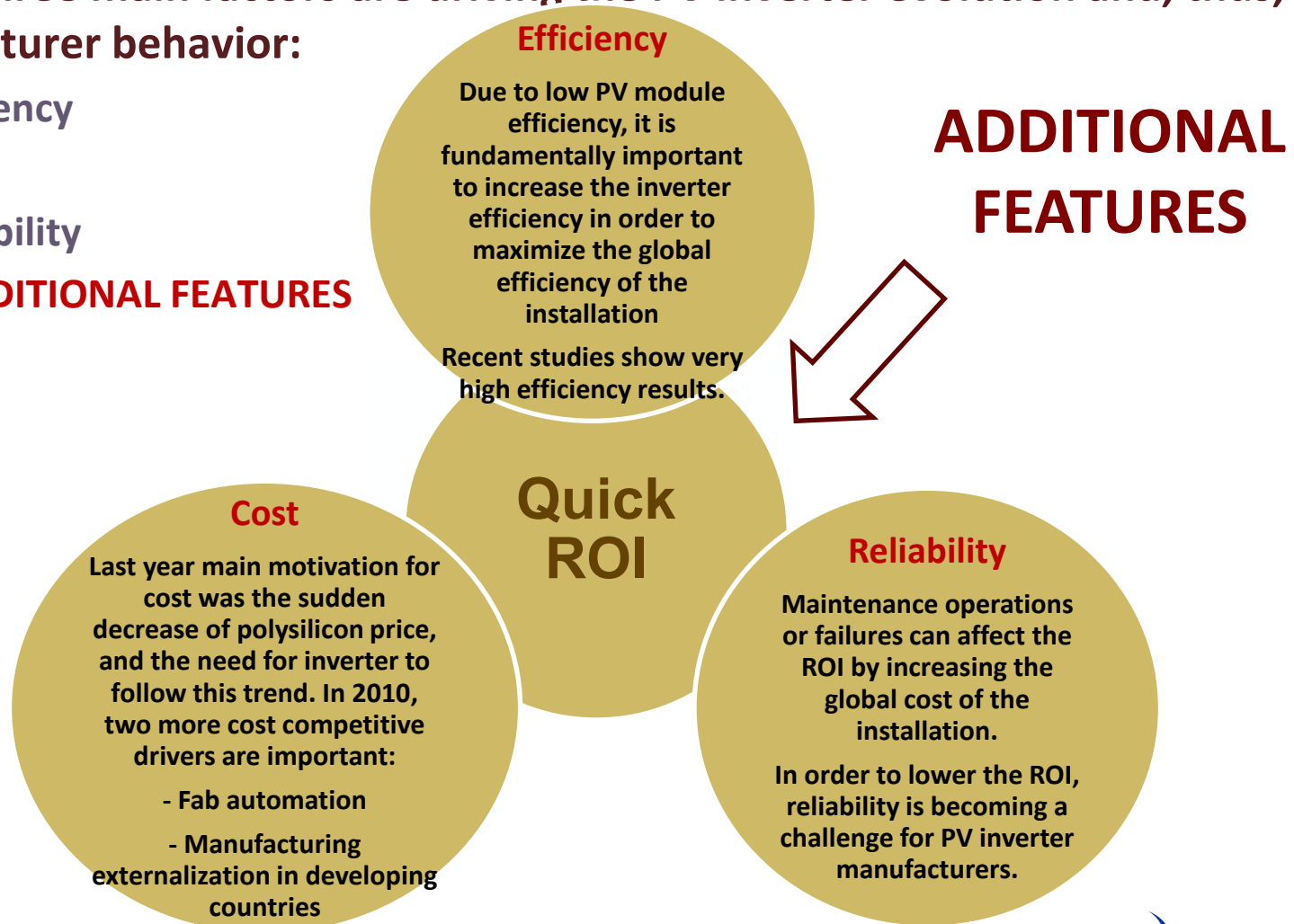

# PV Inverters: the system

## Power electronics

### SiC vs. GaN battle

- Since PV inverter voltage corresponds to the boarder between the utilization of SiC and GaN technologies, it still hard to predict which platform will be adopted.
- Moreover, the efficiency race reaching impressive results, is there a real need to move through those technologies?
  - In 2010 several players have shown an interest in GaN, that we perceive as more adapted to the residential market needs.

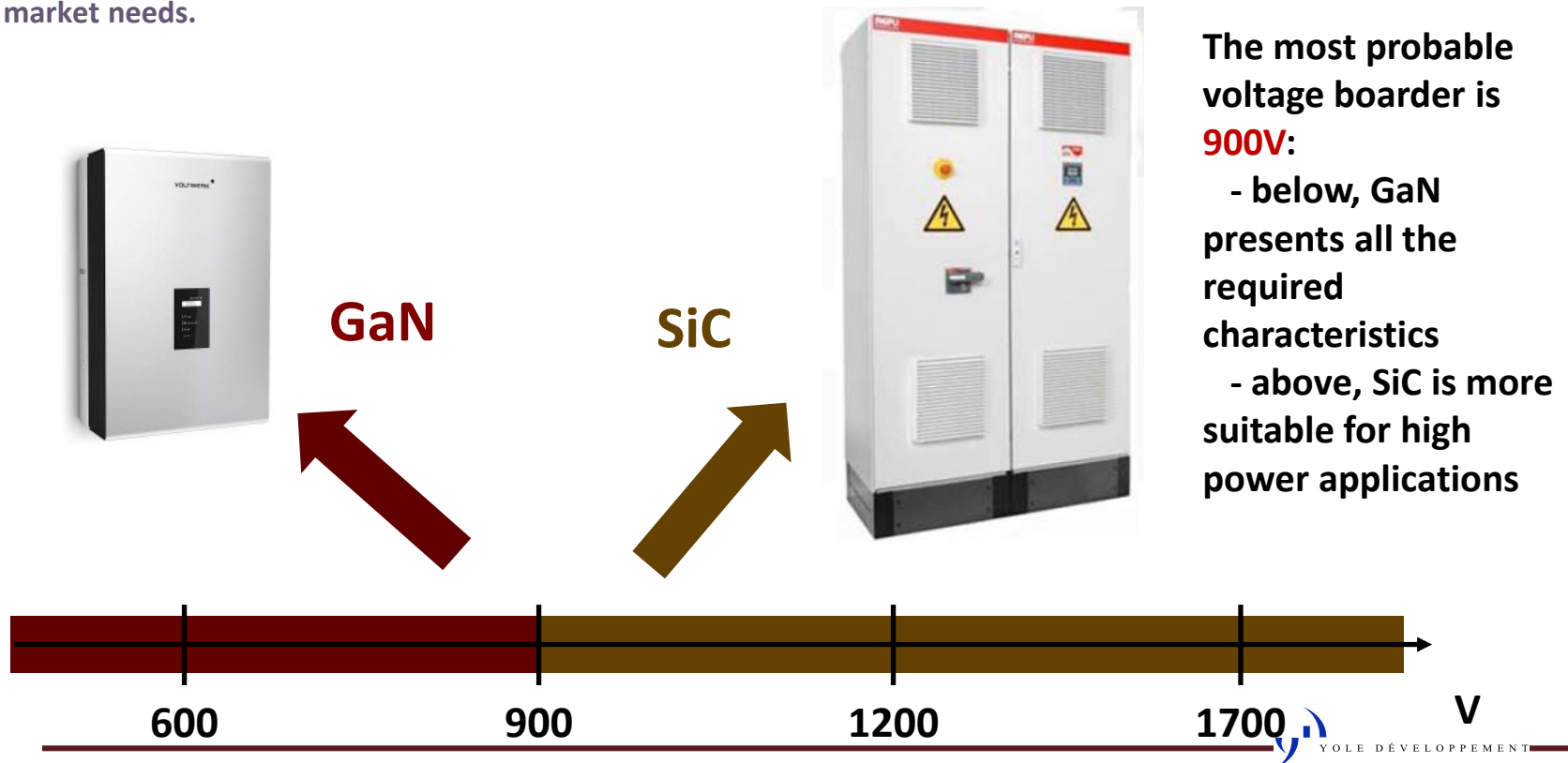

# PV Inverters: the system

## *Power electronics*

GaN device Market for PV Inverters – 6" equiv. GaN substrate market volume (units)

### Hypothesis:

- 1200V/50A die-size: 50 mm<sup>2</sup>
- Surface available: 80%
- Yield: 80%

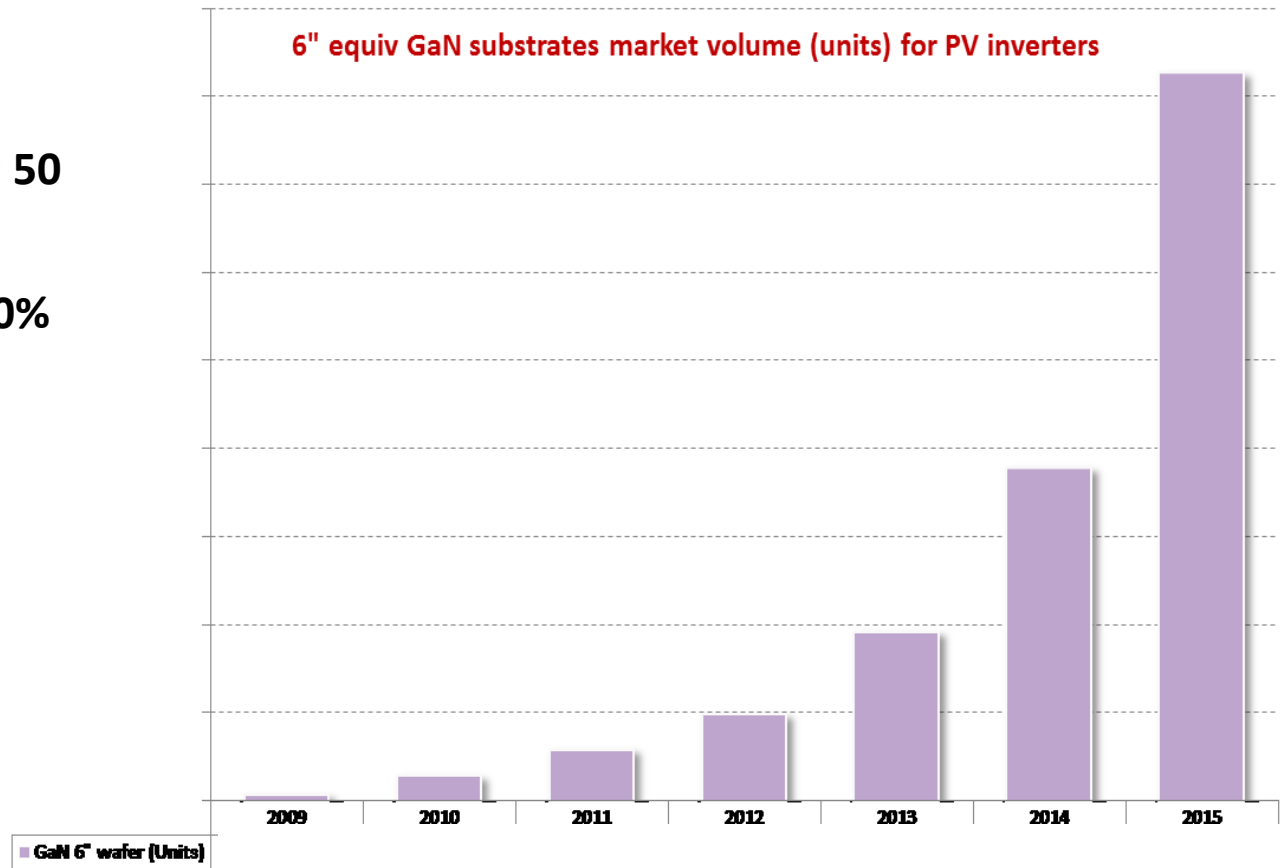

# PV Inverters: the system

## Cost

Cost breakdown of a single string inverter for residential application

- We considered a standard 3–5kW transformerless inverter
- 2010 cost breakdown of a single string inverter for residential application**

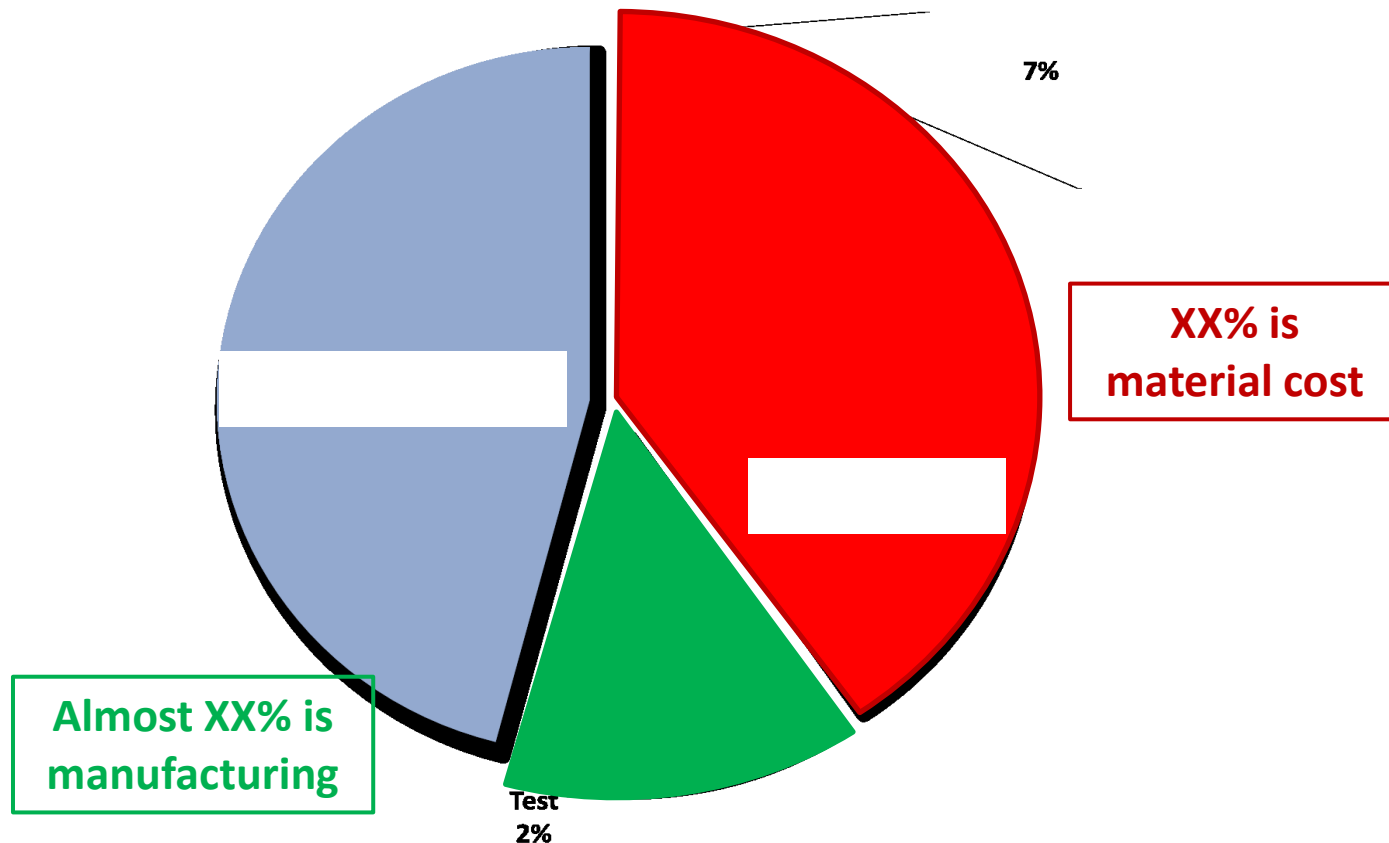

# PV Inverters: the system

## Cost

### Country dependence

- Like all other discriminant parameters, cost (consequently ASP) is less some countries than in others:
  - Chinese manufacturing costs are much lower
  - Fab automation (SMA case) is can drastically decrease operator time

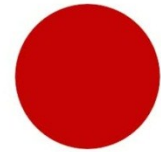

*XX€/W out of manufacture*



*XX€/W out of manufacture*



*XX€/W out of manufacture*



# PV Inverters: the system

## Size

- We had predicted a growth of inverter size for the future years, and we have clearly observed it from 2009 to 2010.

New entrants focus on high power part of the residential segment

→ 4 kW 5kW 7 kW

## Inverter power distribution Comparison between 2008 and 2009

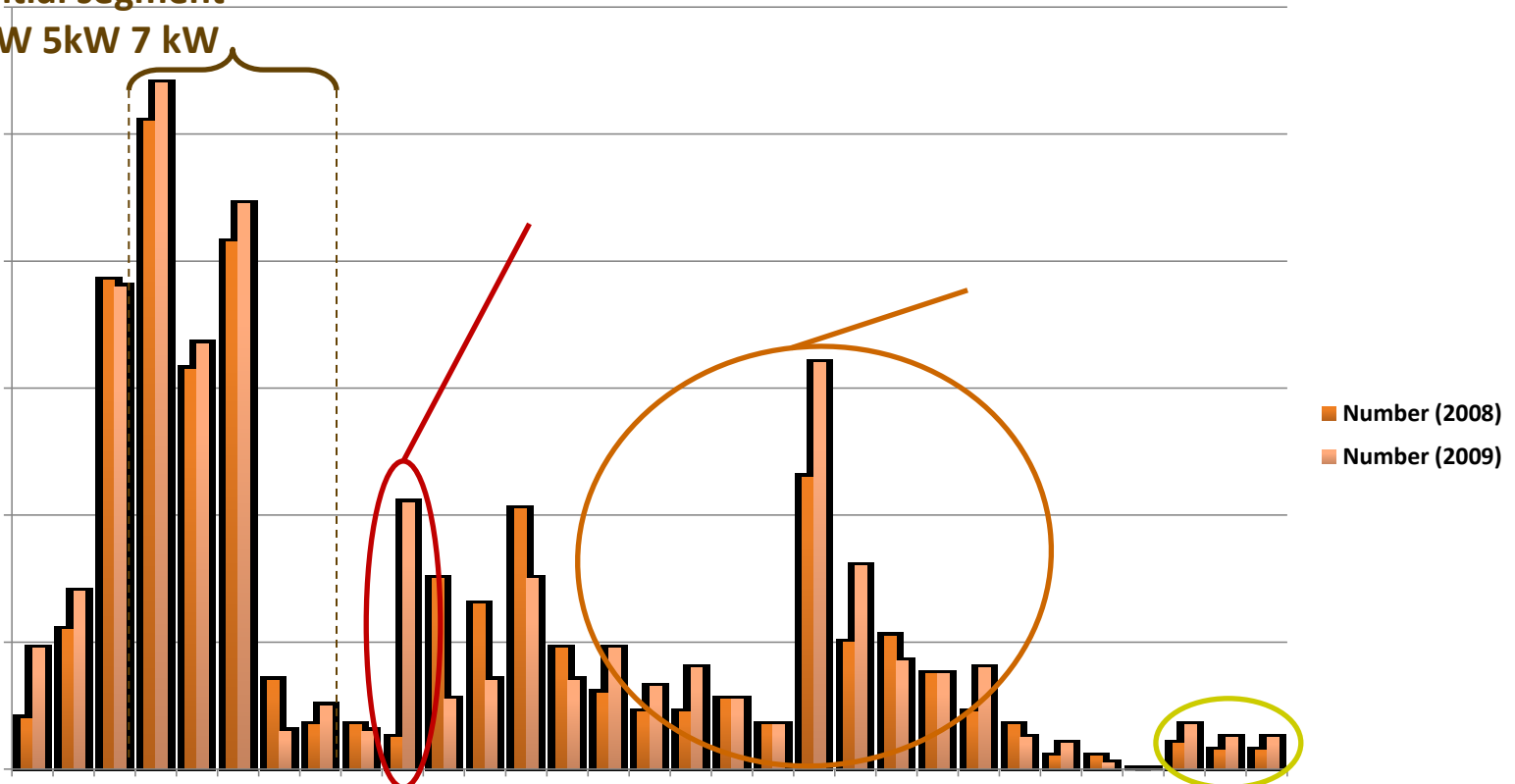



# PV Inverter Environment

## Architectures

### Overview by market segment

Residential

Commercial / industrial

Solar farms

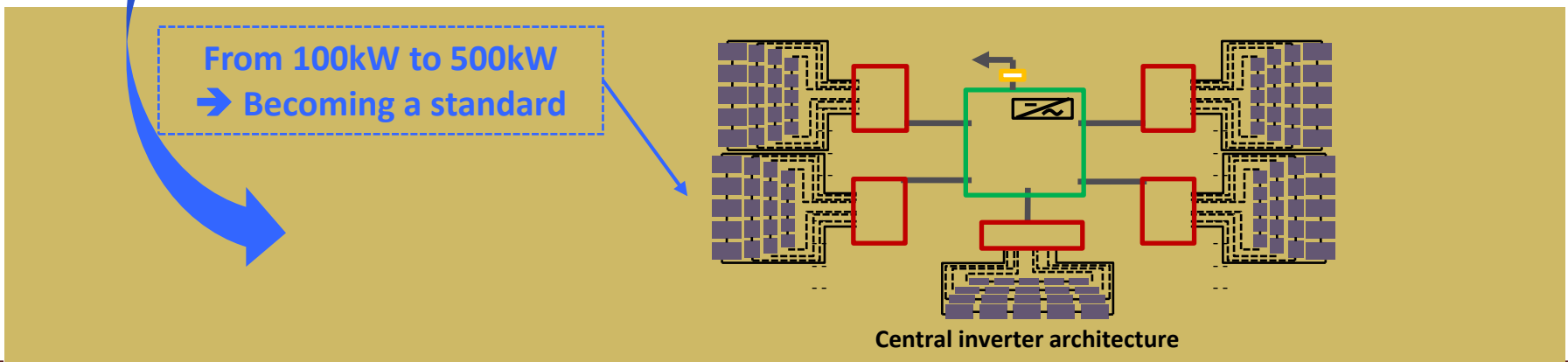
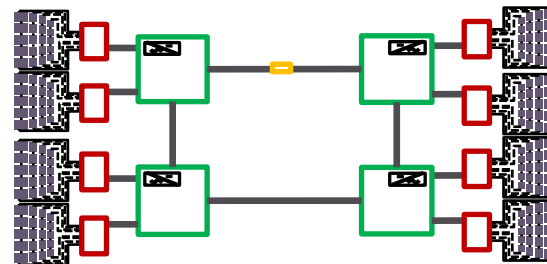
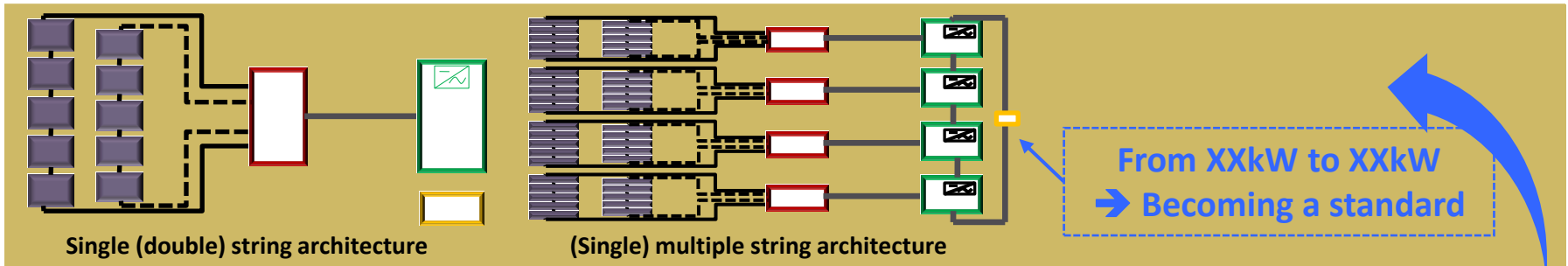

# PV Inverter Business Players

*Penetration strategy status*

Geographical aspect: supply flow

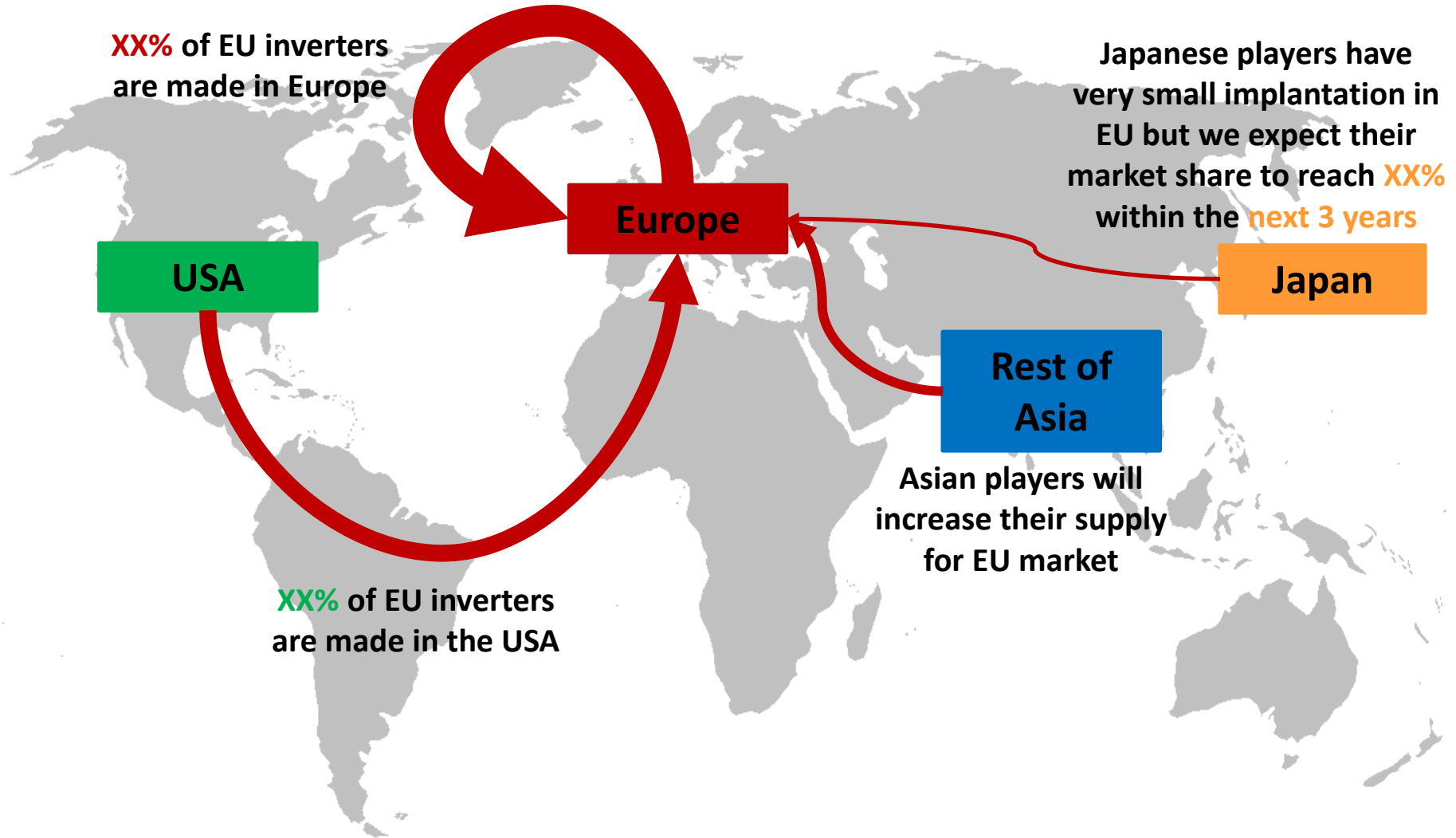

XX% of EU inverters are made in Europe

Japanese players have very small implantation in EU but we expect their market share to reach XX% within the next 3 years

USA

Europe

Japan

Rest of Asia

Asian players will increase their supply for EU market

XX% of EU inverters are made in the USA