

GaN'07

New perspectives for nitride materials and devices



YOLE DÉVELOPPEMENT

Different substrates for GaN epitaxy

“Direct growth or buffer approach” (1/2)



	GaN Sapphire	GaN n-type SiC	GaN S.I. SiC	GaN Bulk-GaN	GaN Silicon	GaN Epi-3C-SiC Silicon	GaN Glass
Epiwafer providers	TDI Hitachi Cable NTT Kyma OptoGaN	CREE Hitachi Cable TDI NTT	CREE Hitachi Cable NTT Toyoda Gosei AZZURO IQE, Kopin Picogiga	Sumitomo SEI Kyma LumiLOG Samsung-corning Hitachi cable AZZURO	Nitronex AZZURO Picogiga IME ; IQE	Toshiba Ceramic (TOCERA)	BluGlass (coop. with Saint-Gobain)
Device makers	Lumileds Osram Nichia Toyoda Gosei Velox	CREE Osram	CREE Fujitsu RFMD Northrop Grumman Kopin IQE Freescale NEC, TriQuint	Sony Nichia NEC	Nitronex OKI TriQuint	R&D	R&D
Application	Blue / white LED Power Devices	Blue / white LED	RF devices	Blue/violet laser diodes	RF devices LED	RF devices Power devices	Blue / white LED
Pros	Low cost 4" possibility	Thermal cond. 4" avail. Back-side contact	Thermal cond.	Defects density	Tc Cost large Ø	Defects density Tc	Low growth T° Cost Up to 6"
Cons	Defects density Thermal cond. No back-side contact	Cost Patents (LEDs)	3" only Cost	Cost 2" only	Defects density Wafer bow	Bow, warpage	Defects density

2001-2012 GaN LED market status and forecast in M\$

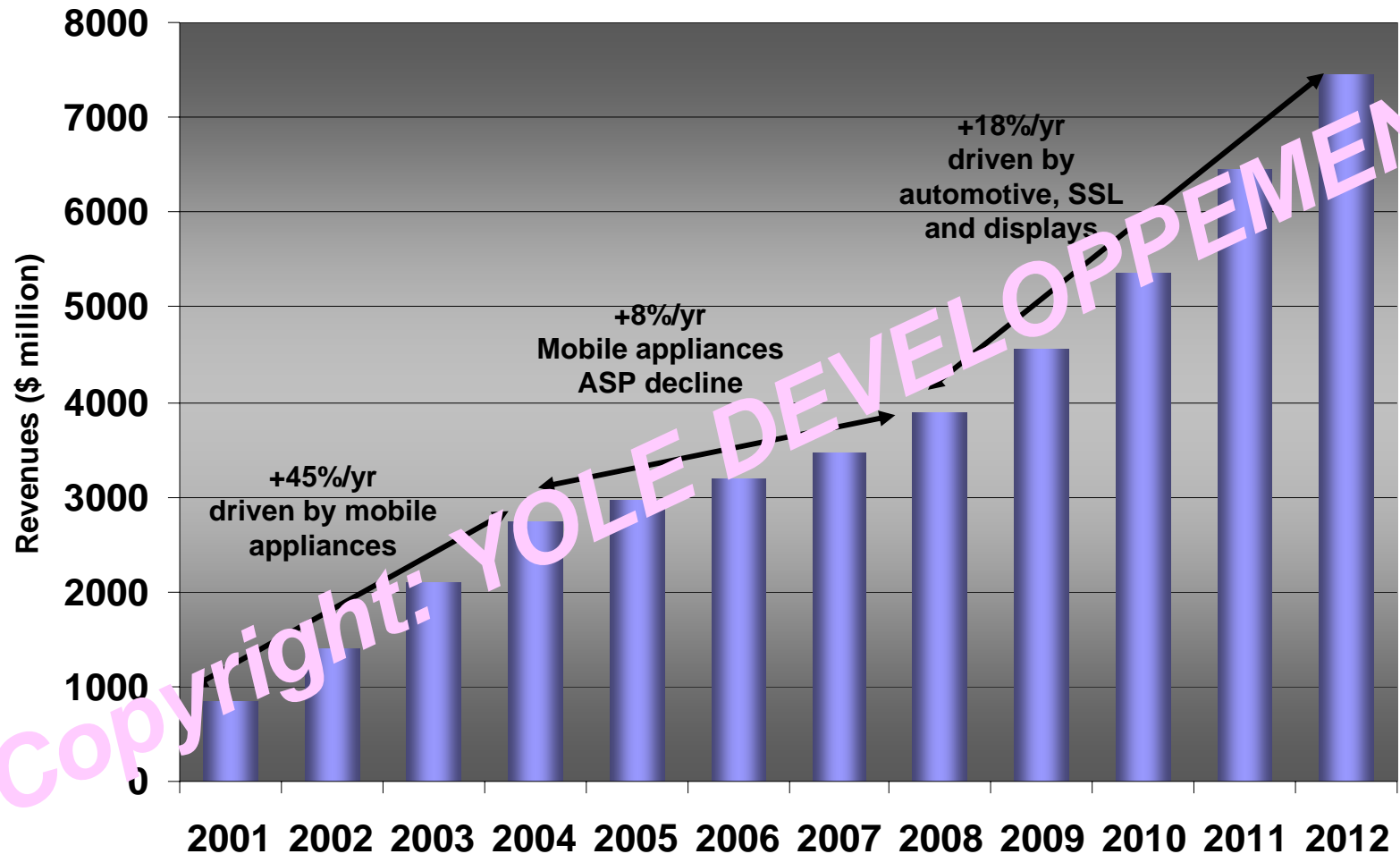

Copyright: YOLE DÉVELOPPEMENT

Main agreements and cross-licenses in LED business

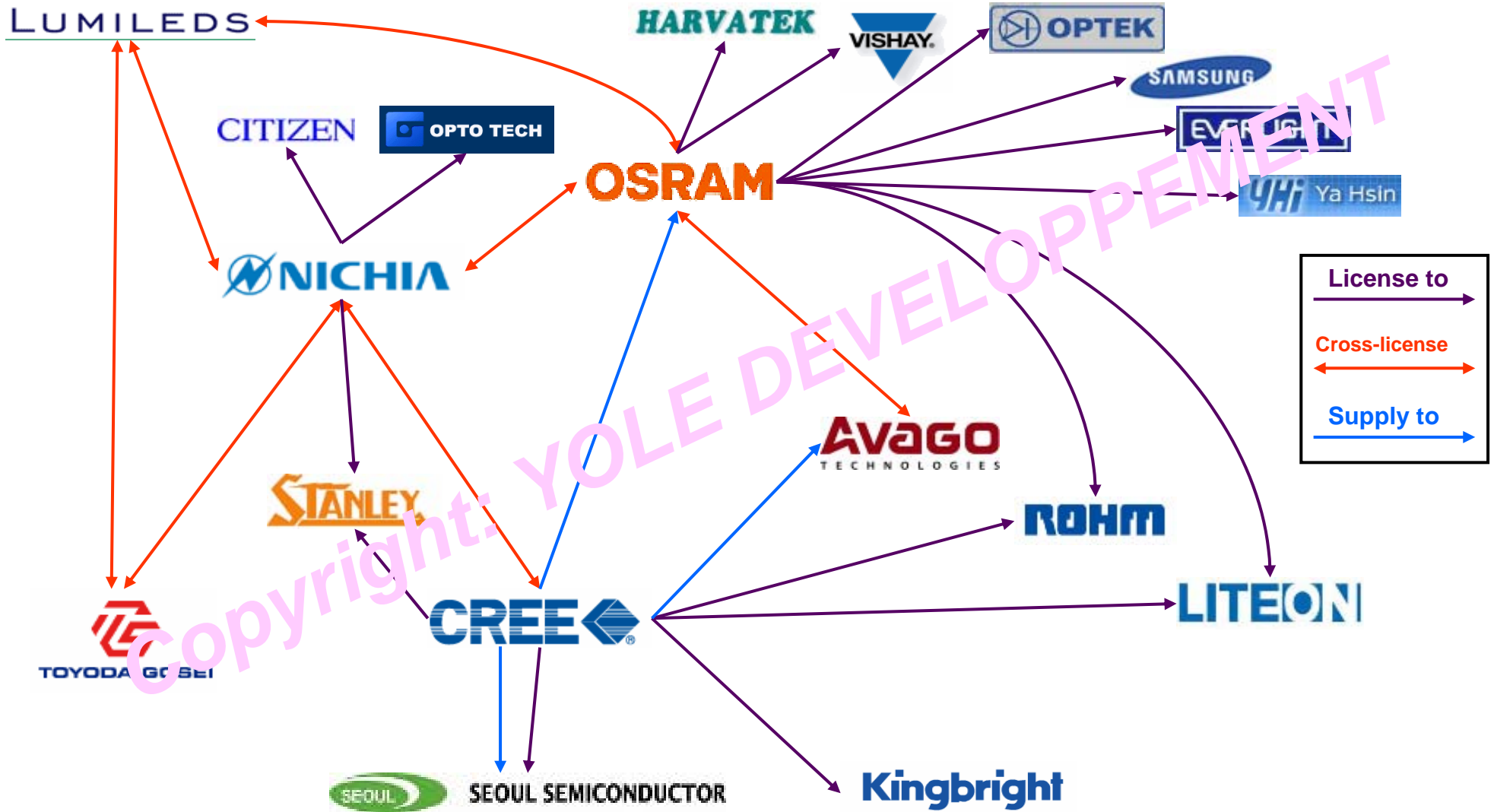

GaN LED Market Generalities

New technologies in development



Market Need

Application

Device

Process

Key players

Need to improve illumination performances

At LED level

Light extraction efficiency

Light directional emission



Laser lift-off

Textured LEDs

Photonic crystals

Photonic crystals

New LED designs

NIL or Holographic

OSRAM

OSRAM

Luminus, OSRAM, LG, LumiLeds

LumiLeds, OSRAM

2006 sapphire substrates market for LED: price, units and diameter analysis

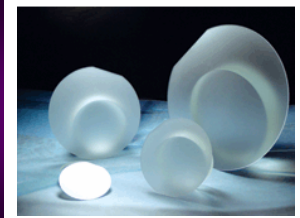

- **2006 Average Selling Price (ASP):**

- **2”:**
 - \$XX-\$XX (Korea, Taiwan or China)
 - \$XX-\$XX (Europe, US)
- **3”:** ~\$XX
- **4”:** ~\$XX

2006 sapphire substrates market in mm² processed.
Breakdown by diameter

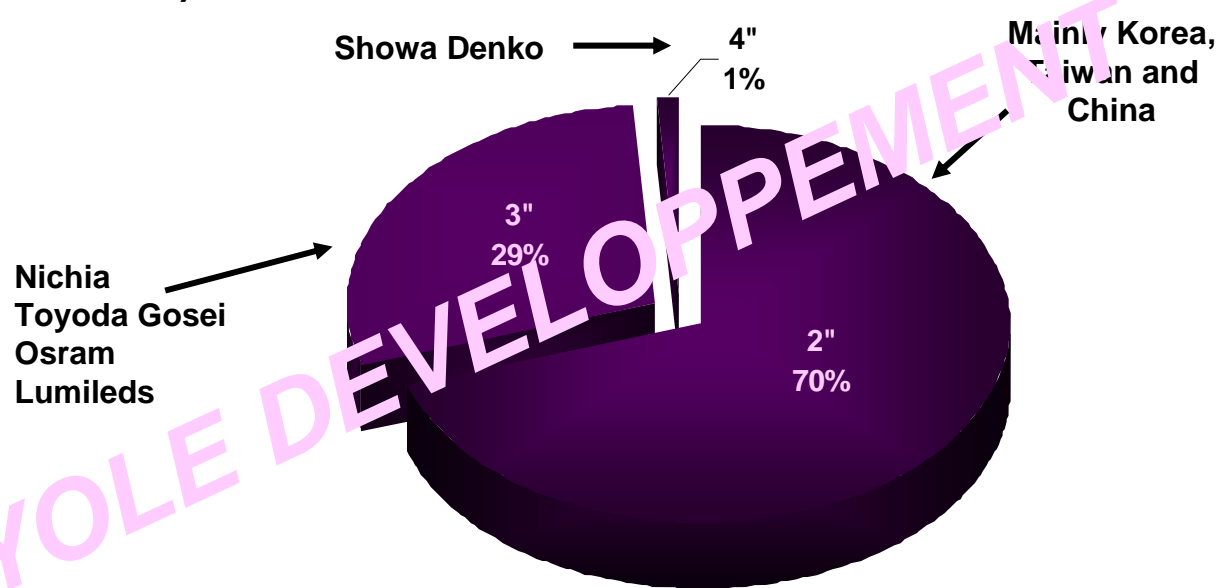

Breakdown over a 2006 total of x,xxx Million mm² processed

SiC wafers diameter evolution for GaN/SiC HB-LED production 2005-2012



2005-2012 SiC substrates diameter breakdown for GaN LED at CREE
(in % of processed surface)

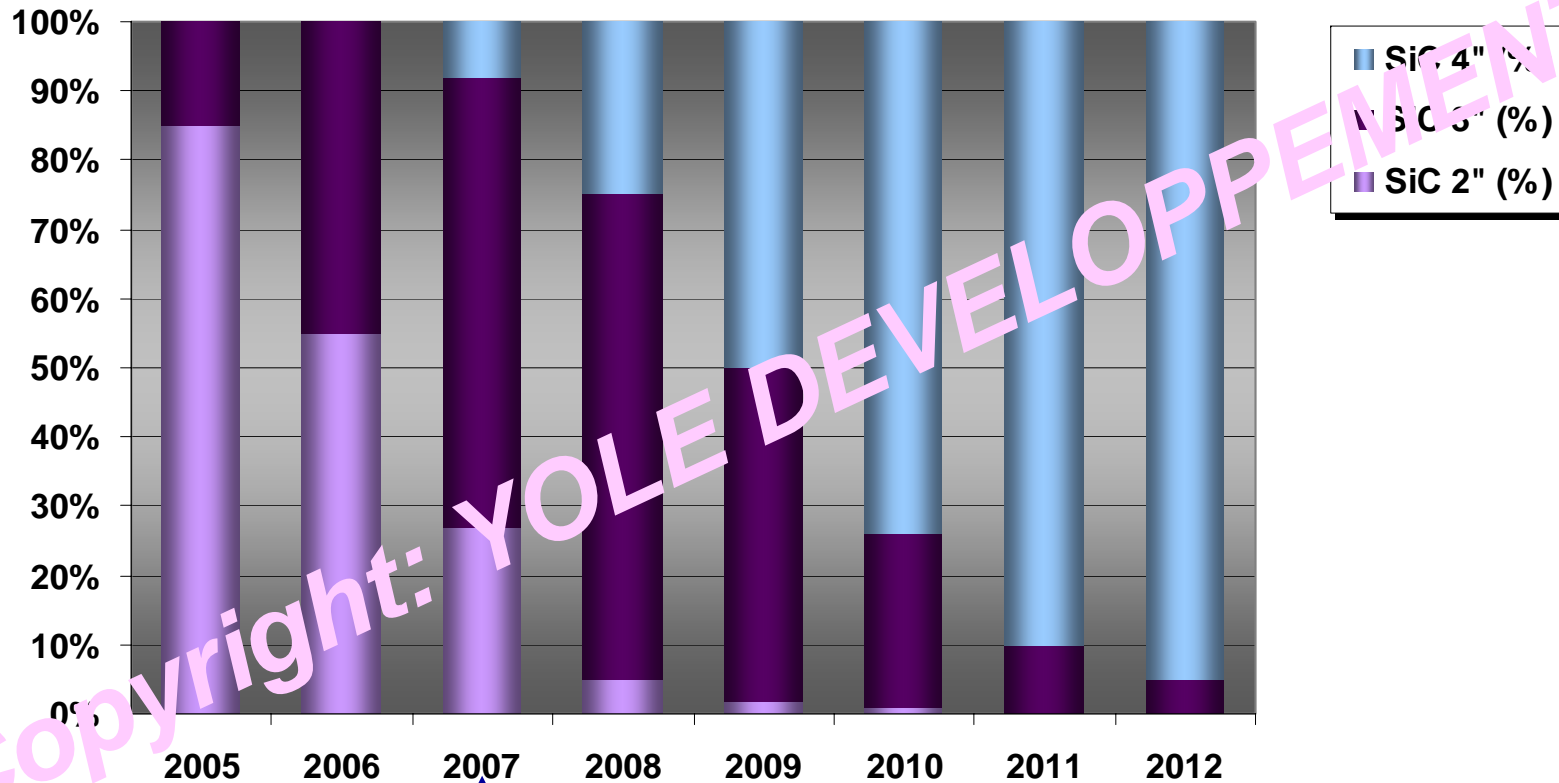

Cree started 4" line

Ramp-up of Cree 4" production

GaN FET commercialization status & announcements

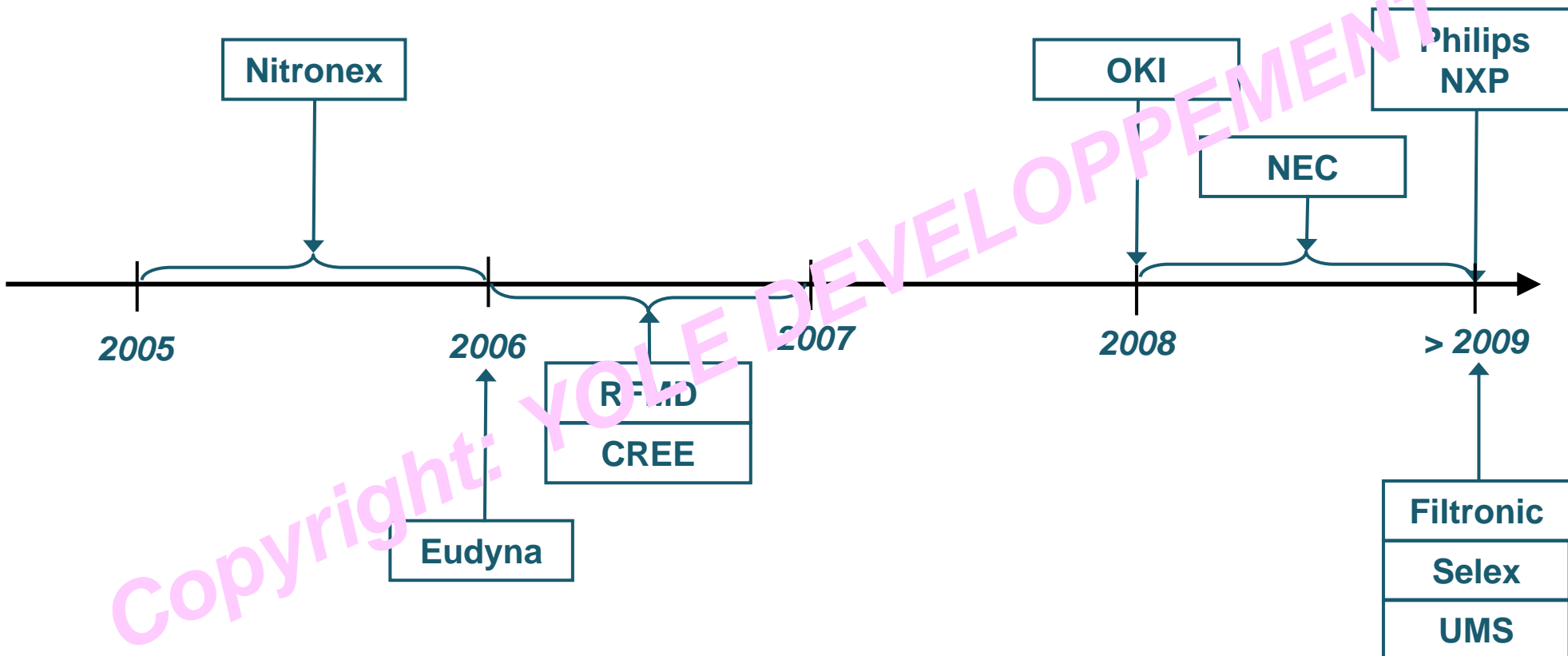
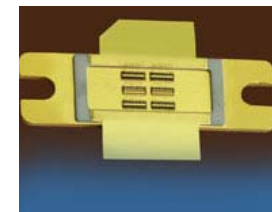

Power Amplifiers (PA) for Base stations (BTS) market

Si LDMOS & GaAs pHEMT 2006 status



- Base station's Power Amplifiers (PA) market was in the range of \$435M in 2006 widely dominated by silicon LDMOS technologies
- Typical base station average RF power is 200-350 watts
 - Typical 2G back-off: 3 dB
 - Typical 3G back-off: 10 dB
- 70% of the PA cost is due to transistors.
 - 12 to 18 transistors in a 100 watts (peak) PA.
 - 8 to 12 PA's in a base station
 - 120 to 360 transistors in a base station

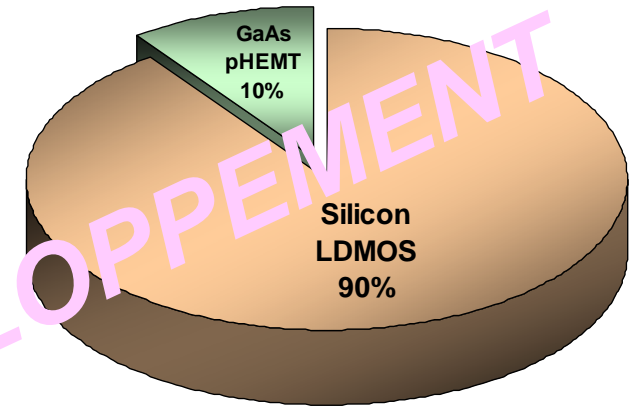

PA's technologies breakdown

Possible applications for GaN devices in power electronics

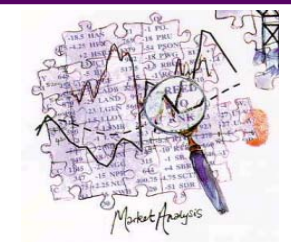

GaN devices in power electronics

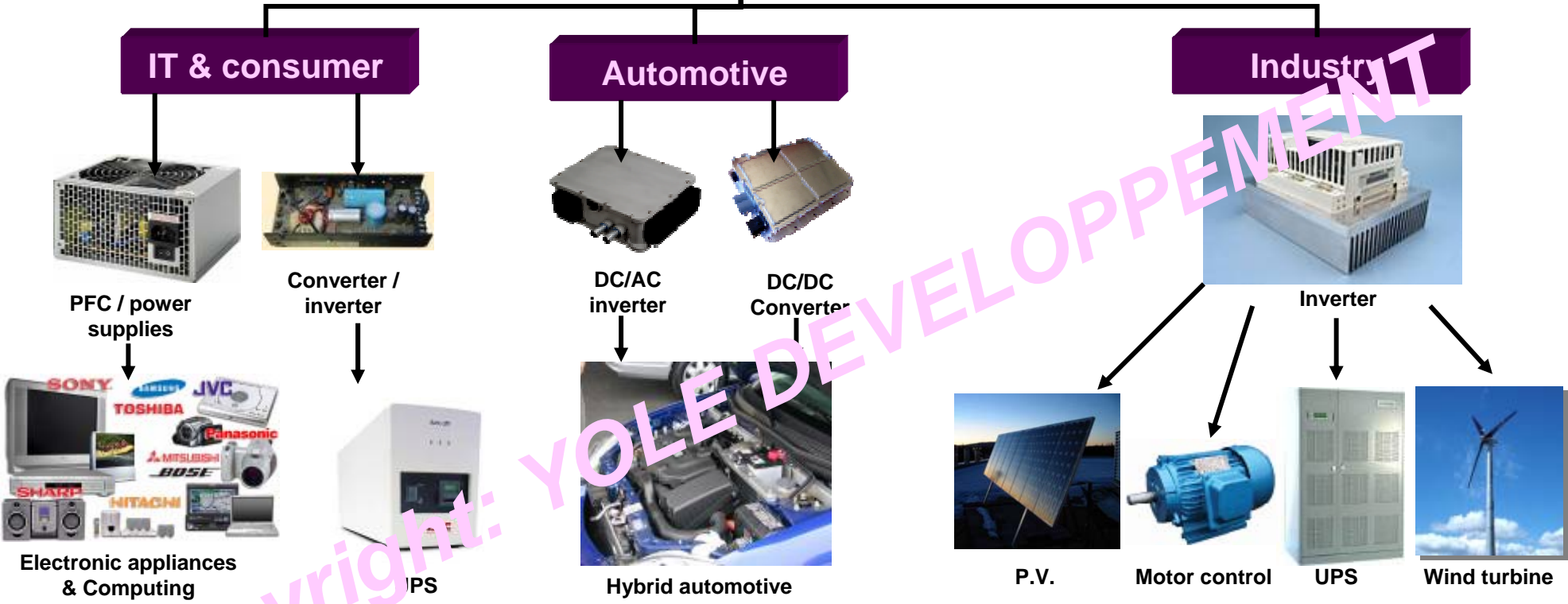

Copyright: YOLE DEVELOPPEMENT



Estimated accessible markets, growth rate, and time to market for GaN based power electronics

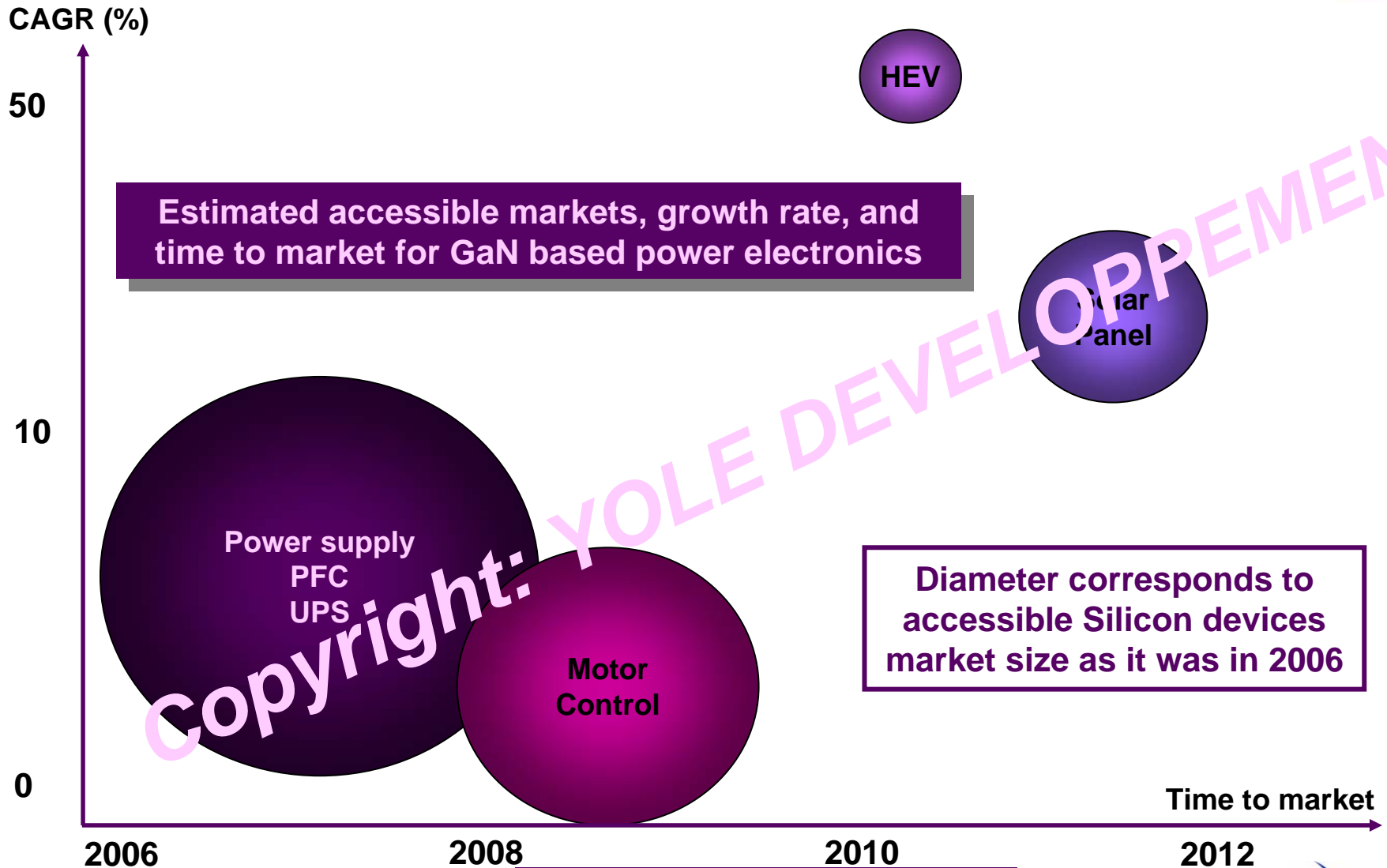
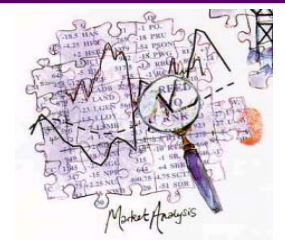

Automotive Application: Hybrid Electrical Vehicle (HEV) requirements.



• DC-DC converter

- Goal: to provide a high voltage (400V) to 12V output, with an option to provide a 42V output.
- Typical power rating: 3 to 10kW with switching frequency of 50-100 kHz

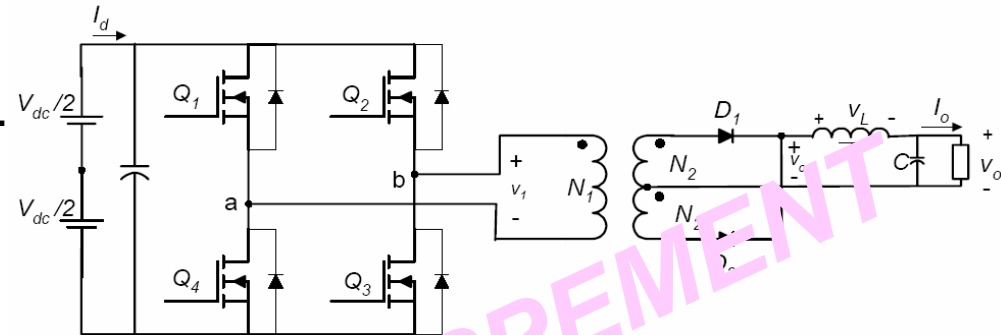

Isolated full-bridge step-down dc-dc converter

• Inverter (DC-AC 3-phases converter)

- Goal: To develop an integrated motor/controller comprised of the motor and inverter in a single package. The goals for the system include an integrated power electronics system capable of 15 years lifetime and capable of delivering at least 55 kW of power for 18 sec and 30 kW continuous power.
- Up to 300 A per motor phase
- Cost < 7\$/kW

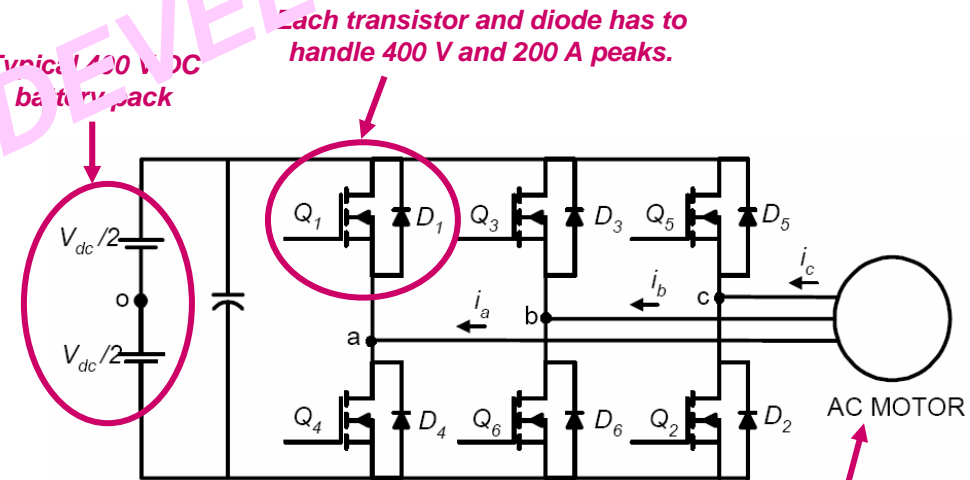

Three-phase inverter traction drive

Typical motor: 30 kW,
230 V, 4-pole, 3000 rpm

2005-2012 GaN devices revenues in M\$ for LED, Laser, RF & power electronics

